

# EPIP-60 SERIES SOLAR CHARGE CONTROLLER

—for solar PV system

## INSTRUCTION MANUAL



Tel: 86-10-82894962

Fax: 86-10-82894882

## 1 Characteristics

- PWM or ON/OFF series charging
- Over-load, short circuit, polarity reverse protection, electronic fuse.
- State of charge(SOC) battery regulation
- Battery Ah setting, boost, equalizing and float charging
- Automatic load reconnection
- Automatic selection of voltage ( 12/24V or 24/48V )
- Temperature compensation
- Accurate clock show
- Lighting control, timer setting options during night time
- Field adjustable parameters by four buttons
- LCD display: SOC as a fuel gauge, all system parameters in digital value, system status as symbols

## 2 Controller panel instructions

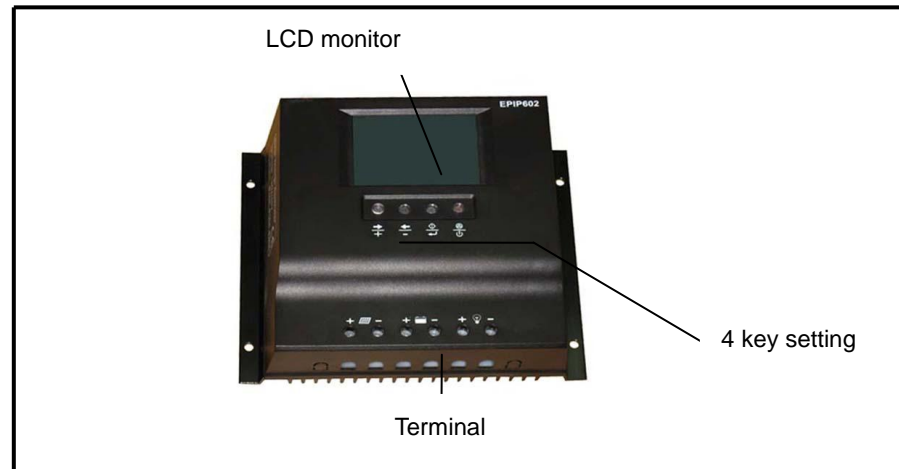

## 3 Installation:

Connect the individual components to the symbols provided, they are solar panel, battery and loads in order. Only install the regulator near the battery on a suitable surface. This surface should be solid, stable, even, dry and nonflammable. The battery cable should be as short as possible

(1-2m) and have a suitable cable diameter size to minimize loss, e.g. use 8mm<sup>2</sup> at 40A; use 10mm<sup>2</sup> at 50A; use 16mm<sup>2</sup> at 60A.

**Observe the following connection sequence during commissioning:**

- 1) Mount the controller to a vertical surface. Allow space above and below the controller for air flow. Note: the mounted ambient temperature should not be over the working temperature of controller (-10°C~60°C);

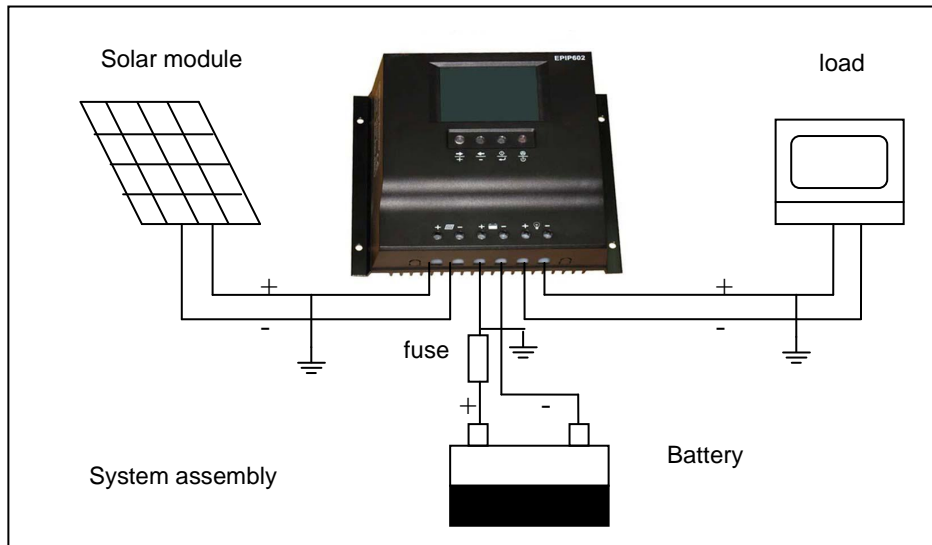

2. Connect the polarity + of battery to the fuse, and then connect the battery to the controller. The current of fuse should be chosen 2-3 times of rated current. Note the plus and minus.
3. Connect the photovoltaic module to the charge regulator - plus and minus
4. Connect the consumer to the charge regulator -plus and minus

**Please observe that the automatic adjustment to 12V/24V or 24/48V systems does not function properly, if this sequence order is not followed. An improper sequence order can damage the battery!**

5. The parameters can be set depending on the user's need.
6. The negative ground(battery) or ground connected as the above.



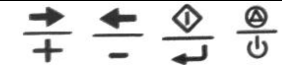



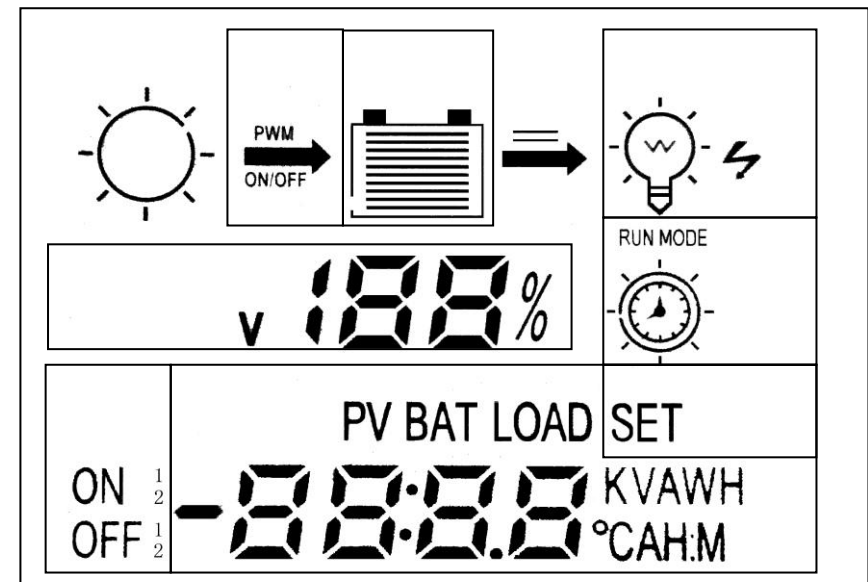





**4. Operation & instructions:**



- 1 Keys & instructions(from left to right):
  - K1: Reading status, switch to next figure; Setting status, switch to next function or increase the setting data.
  - K2: Reading status, switch to the previous figure; setting status, switch to the previous function or decrease the setting data.
  - K3: On reading status, press K3, then on setting status; on setting status, press K3, and save the data, back to reading status.
  - K4: Cancel/power switch, on setting status, no saving with K4. On reading status, K4 is power switch while loads are working. Recovery key while it's short-circuited or over load(with ON/OFF mode).
- 2 Display instructions: LCD display as the setting mark:



- 1) ☀ sun symbol, ☀ on is daytime and ○ on is night time; ☀ flashing shows the over voltage or lighting voltage setting.
- 2) Charging mode . PWM charging or ON/OFF switch; users can choose any method.  
 Note: For telecom or radio, suggest customers choose ON/OFF mode. PWM regulation causes noise interference with such load.

- 3)  battery. The strips inside show the status of charging or discharging and current capacity percentage.
- If discharging, the strips will reduce.
  - If charging, the strips will increase.
  - Without charging or discharging, the strips inside will remain the status.
  - Every strips equals 10% of battery capacity.
  -  shows status of battery.  flashes when over discharging. It stops flashing when goes back to normal charging.
- 4)  DC output.
- 5)  load, shows load and trouble status.
-  is on when the load is in normal,  symbol display when output is on.
  - Load symbol  is flashing when over loading, reduce the load, then press K4 for resume.
  - While short circuit protection, load and light  flashes, return to normal automatically after 10 minutes. If there are 2 short circuit protection in concession in 11 minutes, users need check loads and connects, then press K4.
- 6) LCD displays “PV”, “BAT”, “Load” for solar module, battery or load separately.
- 7) “SET” on goes to selection status, “SET” flashing is on setting status
- 8)   $\frac{1}{2}$ ,   $\frac{1}{2}$ , the on/off switch symbol with **ON/OFF ON EXACT TIME** mode.
- 9)  at bottom of LCD display shows parameters.
- 10)  Displays in lower right: V-Voltage, A-ampere, AH-Battery Capacity, °C-Temperature, H:M-Time, WH-Capacity of charging and discharging in one day.
- 11)  $v$  XX% the percent of available voltage of battery, the current capacity of battery.
- Please observe that the accuracy of the regulator’s display is not comparable to that of a measuring device.*

### 3 Operation instructions:

- 3.1 System is on reading status after its assembly. The LCD display :XX.X v;
- 3.2 Reading specifications: On reading status, press K1, K2, LCD

will repeat the following specifications.

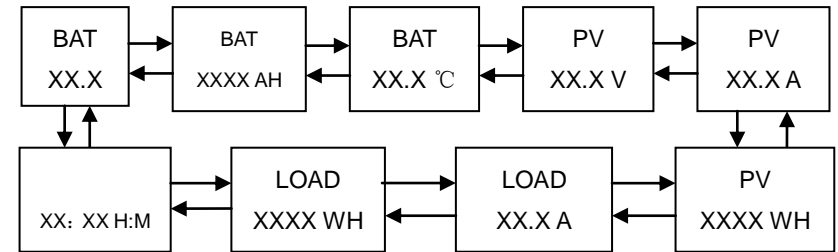





#### 3.3 Battery capacity modify:

While display battery capacity XXXX AH, press K3 into setting mode, battery unit “AH”& “SET” is flashing, modify the data through K1/K2, press one time, battery capacity will be up/down 100, the maximum is 9000, the minimum is 400; Press K3 for saving or K4 for back to the reading status.

The default value is 500AH.





#### 3.4 Charging mode modify:

- 1) While on displaying voltage of solar module, press K3 into setting mode, “SET” is on, and  is flashing, press K1/K2 to select PWM- or ON/OFF- mode;
  - 2) Press K1/K2 into setting lighting start voltage mode,
  - 3) While “SET” and  flashing, press k3, choose the charging mode.
  - 4) K1/K2 switch on PWM or ON/OFF mode
  - 5) K3 for saving, K4 back to original status.
- Go ahead with following procedure while need to set the lighting start voltage
- 6) while “SET” and  flashing, press K3, and set the lighting start voltage.
- Note: the lighting start voltage is from 3.0 to 7.0V. Users can set the voltage within this voltage.**
- 7) Press K4 for saving and back to selection.

The default mode is **PWM**, lighting start voltage is: **5.0V**.

#### 3.5 Load control setting:

Four control mode: **lighting control, lighting+hours on, ON/OFF on exact time, ON/OFF**, When LCD displays load current, press K3 and “SET” flashes. Operate K1, K2 to meet user’s need and press K3 to return to reading status.

- 1) , **lighting control**. The loads will be connected or disconnected automatically, depends on the light that controller detects.
- 2) , **lighting+hours on**. The loads can disconnect automatically depending on selecting working time.
- 3) , **ON/OFF on exact time**. Load on or off on exact setting time.
- 4) Without  or , its **ON/OFF mode**.

### 3.6 Time setting operation:

**Note: users can check and set the time after load control setting only.**

- **ON/OFF mode, lighting control mode**, the LCD shows real time only.
- **Lighting + hours ON mode**, User can adjust real time and working hours.
- **ON/OFF on setting time mode**, user can adjust the exact time for load ON or OFF.
- The default time data is 0.
- The controller will follow the last data setting.

When LCD displays time to be adjusted:

- 1) Press K3, "SET" and H of H:M flashes, user can modify hours
- 2) User can adjust data 0~23 by K1/K2
- 3) Press K3 again, save data of hours and then turn to modify minute, "SET" and M of H:M flashes.
- 4) User can adjust data 0~59 by K1/K2.
- 5) Press K3 and save the modified data, if not saved, then press K4 to return select status-"SET" not flash.

Note: while its on **LIGHTING+HOURS ON** mode, adjust happens after it started work, the controller will follow the instruction on the next day.

## 5 Safety and Protection

The controller is with intelligent protection against over voltage, over current, short circuit, polarity reverse and lightning. The LCD displays have warning indicates of over voltage, over current and short circuit.

Note: TVS lighting protection is the last necessary protection. User need choose professional TVS system in the areas with frequent lightning weather. If the controller without TVS system is damaged by lightning, it will not be guaranteed.

## 6 Guarantee & Customer service

One year warranty, or contact your authorized distributor. Used improperly

and damaged by people, the controllers are not guaranteed.

## 7 Specifications

Type	EPIP-60-I40	EPIP-60-I50	EPIP-60-I60
Rated charging current	40A(max46A)	50A(max59A)	60A(max69A)
Rated load current (Ie)	40A	50A	60A
Over load, short circuit protection	1.25 times of Ie for 60secs, 1.5 times of Ie by for 5secs overload protection; ≥2 time of Ie short circuit protection		
Self consumption	Control mode: <15 mA, LED & LCD display <15mA. Total: <30mA		
System voltage	12/24V or 24/48V AUTOWORK,		
Work temperature	industrial (I series): -20°C to +70°C		
Battery capacity	Battery in parallel from 50AH to 5000ah		
Boost charging	14.8V; x2/24V; x4/48V		
equalizing charging	14.4V; x2/24V; x4/48V		
Float charging	13.4V; x2/24V; x4/48V		
Temperature	5mv/°C/2v;		
Over discharge voltage	11.4V; x2/24V; x4/48V		
Control mode	PWM charging mode & ON/OFF mode for options, control point voltage is the intelligent compensation modify of the battery.		

## 8 Problems & Troubleshooting:

Problems	Troubleshooting
Sun symbol flashing without setting	Battery over voltage. Open circuit of battery. Check if the battery cable connect properly, or disconnect all components and reconnect.
The load symbol flashing	Overload occurs, remove some loads and then press K4.
Load and short circuit symbol flashes	Short circuit protection, check if the loads connect properly, remove some loads with trouble and then press K4.